

# RSCDS Manchester Xmas Dance 2018

## 1 CURRIE MOUNTAIN R32 · 3/4L

Mary Pugh: *New Brunswick Collection* · Crib: *E-cribs* · Diagram: *Keith Rose's Diagrams*

- 1- 1c cross RH, cast off one (2c up) ;  
½Fig8 up round 2c (2,1,3)
- 9- 1c (start inwards) turn 3C EH ; 1c turn  
2C EH (2,1,3)
- 17- 1c+3c RHA ; 1c+2c LHA
- 25- 2c+1c+3c Reels3 on the sides, 1c  
giving Rsh to 3c (2,1,3)

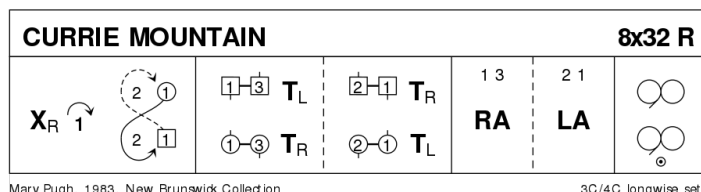

After the second turn the dancing couple continues the reel with bottom couple to change places.

## 2 TRIBUTE TO THE BORDERS J32 · 3/4L

Roy Goldring: *The Leaflet Dances with Music* · Crib: *E-cribs* · Diagram: *Keith Rose's Diagrams*

- 1- 1c cross RH | cast (2c up) ; turn 1¼  
RH to promhold facing M side
- 9- 1c Rsh ½Reel3 with 2M+3M ; Rsh  
½Reel3 with 3W+2W, 1c finish in  
centre facing 3W (now in 1W pl)
- 17- 1c set to 3W pulling Rsh back | set to  
2W ; set to 2M | 1c set to 3M **while**{2} 3c+2c set advancing into
- 25- 3c+1c+2c Allemande

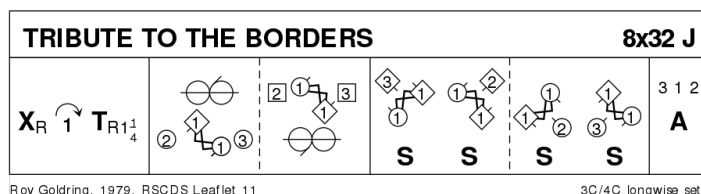

## 3 MISS GIBSON'S STRATHSPEY S32 · 3/4L

Derek Haynes: *The Leaflet Dances with Music* · Crib: *E-cribs* · Diagram: *Keith Rose's Diagrams*

- 1- 1c+2c set | turn BH ; circle4 L
- 9- 1c+2c Knot, 1c finish facing 1cnrs
- 17- Turn CPCP, with final wide ¾ LH turn  
into
- 25- Teapots R and L (1M+3c & 1W+2c  
RHA, 1c pass Rsh, cnrs not to  
sidelines ; 1M+2c & 1W+3c LHA) (2,1,3)

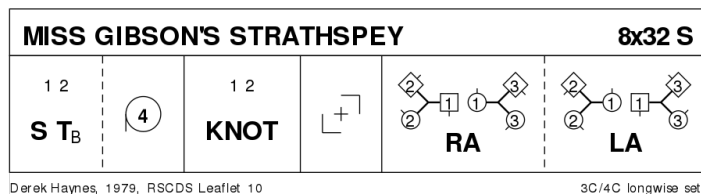

## 4 ROUND REEL OF EIGHT R88 · 4S

RSCDS XXVII 7 · Crib: E-cribs · Diagram: Keith Rose's Diagrams

- 1- All W cast by the R and round the set to places
- 9- All M cast by the L and round the set to places
- 17- G-Chain halfway round {6} | all set to P
- 25- Continue G-Chain to places {6} | all set to P
- 33- 1c & 3c change places, 1c passing inside {3}, repeat back to places, 3c passing inside {3} | 1c+3c turn RH 1¼ into Allemande hold
- 41- 1c+3c (passing Lsh) Promenade cclw round inside of set to places
- 49- 2c+4c repeat [33-48] (2c pass inside first)
- 65- 1c+3c half R&L ; 2c+4c half R&L
- 73- Repeat [65-72] (to 1,2,3,4)
- 81- All Circle8 and back

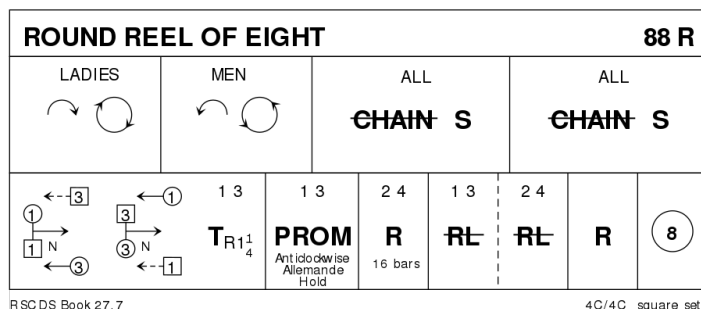

## 5 GAELFORCE WIND J32 · 3/4L

Derek Haynes: A Third Book of Graded Scottish Country Dances · Crib: E-cribs · Diagram: Keith Rose's Diagrams

- 1- 1c set and cross RH, 1c+2c S&Link, 2W+1W finish facing out. (2,1x,3)
- 9- 2c+1c M-Chain.
- 17- 1c ½ Fig8 L (Rsh to 4cncr) ; All turn RH (2,1,3)
- 25- All Circle6 and back (2,1,3)

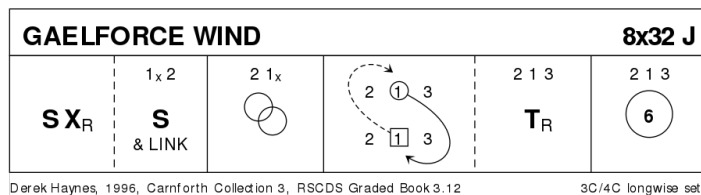

## 6 RED KITES OVER THE BLACK ISLE S32 · 4/4L

Ann & Ian Jamieson: The Glen Orrin Collection · Crib: MiniCribs · Diagram: Keith Rose's Diagrams

- 1-8 1s & 4s set & cast in 1 place (2s & 3s step up/down), 1s+4s dance 1/2 R&L
- 9-16 2s & 3s set & cast in 1 place (4s & 1s step up/down), 2s+3s dance 1/2 R&L. (4) (3) (2) (1)
- 17-24 4s+3s & 2s+1s dance RH across, 3s+2s dance LH across **while** 4s & 1s chase clockwise to other end
- 25-32 1s+3s also 2s+4s set facing on sides & change places RH, turn partners 2H to own sides (end couples turn 1.1/2 times)

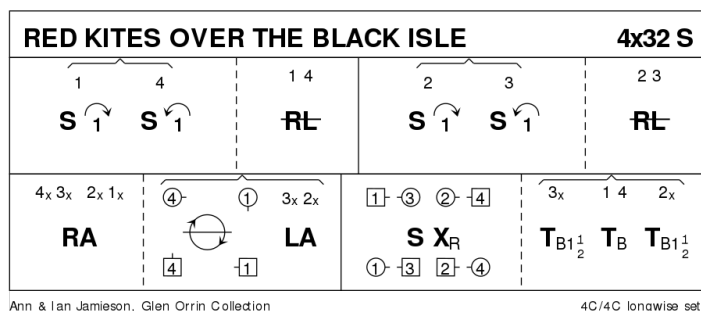

## 7 MISS JOHNSTONE OF ARDROSSAN R32 · 5/5L

Roy Goldring: 14 Social Dances for 2000 · Crib: E-cribs · Diagram: Keith Rose's Diagrams

- 1– 1c set | cast off (2c up) ; 1c followed by 3c dance up and cast round 2c to (2,3,1,4,5)
- 9– 1c+4c+5c mirror Reels3, 1c cross down to enter, 4c start out and up (2,3,1x,4,5)
- 17– 2c+3c+1c mirror Reels3, 1c cross up to enter, 3c start out and down
- 25– 1c set | cast off to 4pl (4c up) ; 1c followed by 5c dance up and cast round 4c to (2,3,4,5,1)

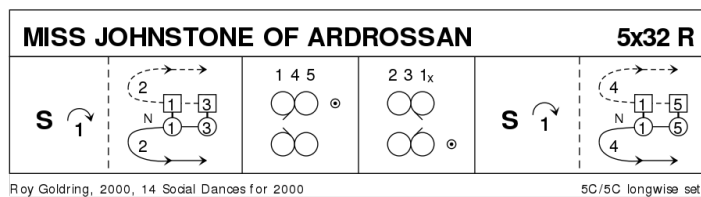

## 8 GOOD HEARTED GLASGOW J32 · 3/4L

Peter Knapman: Collins Pocket Reference: Scottish Country Dancing · Crib: E-cribs · Diagram: Keith Rose's Diagrams

- 1– 1c turn RH | cast off (2c up) ; turn LH 1¼
- 9– Teapots R ; and L (2c+1W & 1M+3c RHA ; 2c+1M & 1W+3c LHA)
- 17– 1c lead down the middle and up into 2pl
- 25– All circle6 and back



## 9 PROGRAMME ITEM – Interval

## 10 THE RAVEN'S DANCE J32 · 3/4L

Derek Haynes: Carnforth Collection of SC Dances 5 · Crib: E-cribs · Diagram: Keith Rose's Diagrams

- 1– 1c+2c DbIFig8 (1c cross down, 2c dance up, no cast), at the end 2c face out
- 9– Crossover Reels3 on the sides (1c cross down, 2c out and up), finish 1c side by side at top facing down, W on the R, 2c facing out
- 17– 1c (together) +2c Lead-change Reel3 across, Rsh to 2M. 2c finish in 1pl with 1c in between facing down
- 25– 1c dance down, cast up round 3c, lead up, cross between 2c and cast off (2,1,3)

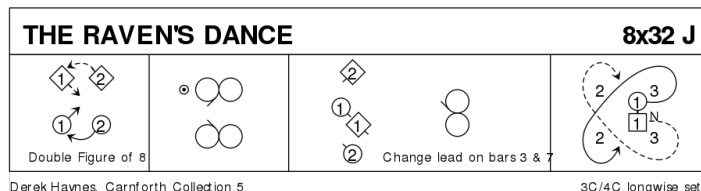

## 11 LADY SOPHIA LINDSAY R32 · 4/4L

Jean Attwood: Alexander Leaflets · Crib: E-cribs · Diagram: Keith Rose's Diagrams

On 2nd chord 3c+4c cross to (1,2,3x,4x)

- 1– 2c+3c RHA ; 2W & 3W with P following cast L round 1W & 4W »=2cnrs«
- 9– 1M+2c & 3c+4M RHA ; 1W+2c & 3c+4W LHA
- 17– 2c (on M side) & 3c (on W side) (still in tandem, W leading) opposing Reels3 on sidelines, Lsh to 4W/1W “=4cnr”, to 2,1,4x,3x, middle Cs facing each other up/dn
- 25– 1c+4c set | cross RH on side ; set to P | cross RH (2,4,1x,3x)

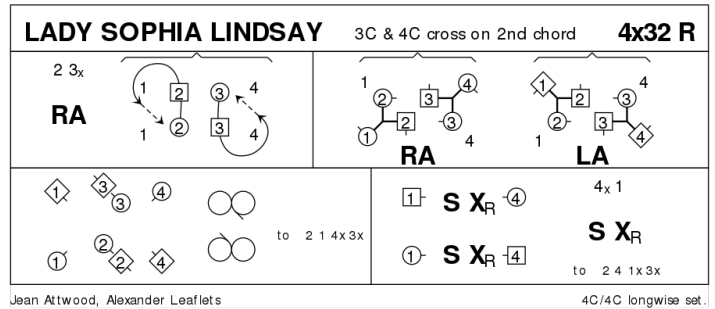

## 12 THE ROSE OF THE NORTH S32 · 3/4L

Roy Goldring: Silver Jubilee 25 - Leeds Branch · Crib: E-cribs · Diagram: Keith Rose's Diagrams

- 1-4 1c lead down, cross below 3c and cast up into 2plx (2c up)
- 5-16 2c+1c+3c R&L for 3 couples
- 17– 1c set to and turn corners, to finish BtoB in the centre, 1M facing up, 1W facing down
- 25– 1M+2c & 1W+3c Circle3 L (at end 1c pull Rsh back to face P) ; 1c set, petronella to 2pl

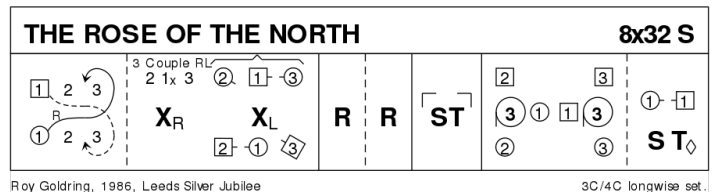

## 13 MRS STEWART'S JIG J32 · 3/4L

Frans Ligtmans: RSCDS XXXV 1 · Crib: E-cribs · Diagram: Keith Rose's Diagrams

- 1– 1c set | 1W casts, 1M following, round 3W, 1W dances up round 3M and 1M dances up the middle, 1c face 3c (2c up on 7-8) (2,1x,3)
- 9– 2c+1c+3c G-Chain (2c cross), 2M+1M finish facing out
- 17– 2c+1c L-Chain
- 25– 2c+1c+3c A&R ; 1c turn RH 1½ to (2,1,3)

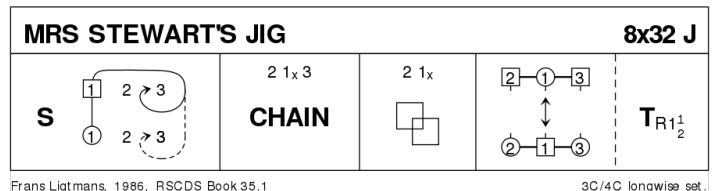

## 14 THE REVEREND JOHN MACFARLANE R32 · 4/4L

Gary W Morris: RSCDS XXXVII 1 · Crib: E-cribs · Diagram: Keith Rose's Diagrams

- 1– 1c cross down into Mirror Reels3 on opposite sides with 2c+3c (1x,2,3)
- 9– 1c ½ Fig8 round 2c ; 1c (BHJ) slip down to between 3c | set (top foot starting) (2c+3c up, 4c step in)
- 17– 1c+4c Pousette (2,3,4,1)
- 25– 2c+3c & 4c+1c RHA ; all C turn LH (3M polite L turn into next repetition).

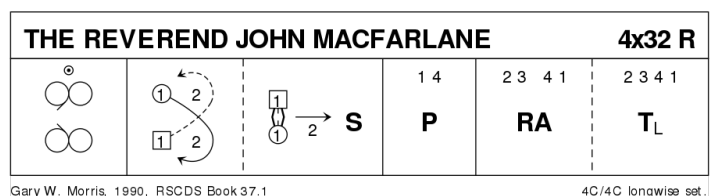

## 15 CULLA BAY S32 · 4S

Ann Dix: RSCDS XLI 2 · Crib: E-cribs · Diagram: Keith Rose's Diagrams

- 1- 1c+3c turn RH ½ with person opposite, face that person | twirl R and into opposite place ; 2c+4c repeat this and face in **while**{4} 1c+3c (W leading) chase ¼ clw | curve into centre and swivel R to face out (1c facing 4pl and 3c facing 2pl)
- 9- Parallel Reels4 across
- 17- 2c+1c & 3c+4c circle4 L ; face other couple and set | ½ RHA, flowing into
- 25- 2c+4c LHA in the middle ; dance out passing same sex standing dancer on the side Rsh, and chase R (M leading) to 1pl/3pl (to 2,3,4,1).

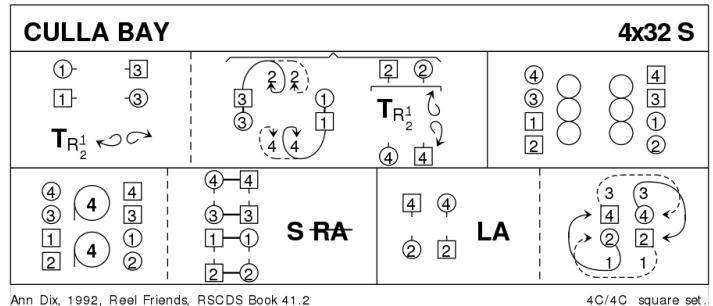

## 16 THE HAZEL TREE J32 · 3/4L

John Drewry: New Dances by John Drewry 2005 · Crib: E-cribs · Diagram: Keith Rose's Diagrams

- 1- 1c+2c Espagnole, 1c finishing facing 1cnr
- 9- 1c turn 1cnr RH, pass Rsh ; turn 3cnr LH, pass Lsh (cnrs dance for {4})
- 17- Turn 2cnr RH, pass Rsh ; turn 4cnr LH, pass Lsh to 2plx side by side facing down
- 25- Lead LHJ between 3c, cross and cast to 2pl ; All C turn RH

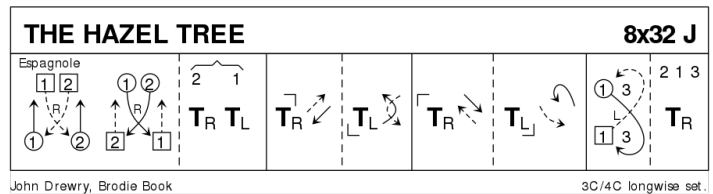

Espagnole: both W lead RHJ to M side, cross and cast back to exchanged places while{} Men cross to W side, lead RHJ back to M side and cross to exchanged places ; all turn P EH (2,1)

## 17 THE REEL OF THE 51ST DIVISION R32 · 3/4L

James Edward McCartney Atkinson: RSCDS XIII 10 · Crib: E-cribs · Diagram: Keith Rose's Diagrams

- 1- 1c set | cast off two places (2c up) and lead up to 1cnrs
- 9- 1c set to 1cnr | turn 1cnr RH and join LH in the middle ; BiL | turn 1¼ LH to 2cnrs
- 17- Repeat with 2cnrs | cross to (2,1,3)
- 25- 2c+1c+3c circle6 and back.

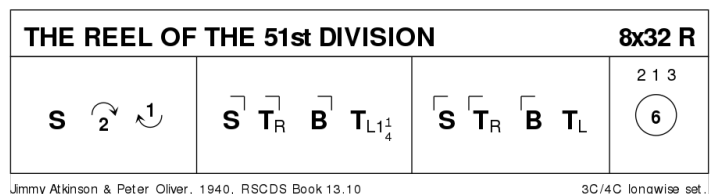

## 18 THE MONTGOMERIES' RANT

R32 · 3/4L

Castle Menzies (18C): RSCDS X 1 · Crib: E-cribs · Diagram: Keith Rose's Diagrams

- 1- 1c cross RH | cast off (2c up) ; cross LH | cast L (W up, M down)
- 9- 2c+1W & 1M+3c Rsh Reels3 across
- 17- 1c NHJ set to 2W (swivel ½ inwards), set to 3M (veer L together), set to 3W (swivel ½ inwards), set to 2M (and face own 2cnr)
- 25- Reels3{6} on the sides, Rsh to 2cnr | 1c cross RH to 2pl

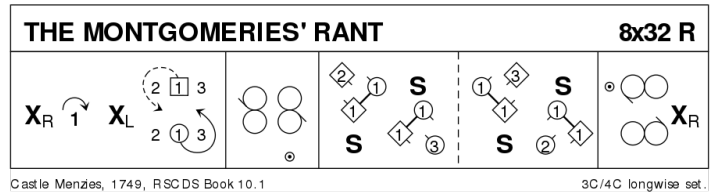

## 19 ST ANDREW'S FAIR

J32 · 3/4L

Roy Goldring: Five Scottish Country Dances 1982 · Crib: E-cribs · Diagram: Keith Rose's Diagrams

- 1- 1c cross RH | cast off 2 (2c up) ; cross LH and cast up (2,1,3)
- 9- All turn RH ½ | retain hold & set ; all chase clw to own sides (3,1,2)
- 17- 3c+1c+2c Circle6 and back
- 25- All turn LH ½ | retain hold & set ; all chase cclw to (2,1,3)

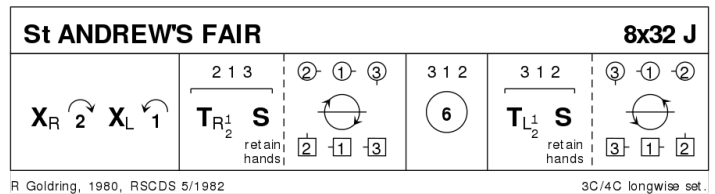

*note: 3c does not move on bars 1-8.*