

RSCDS Manchester Beginners Dance 2019

1 FIONA'S FANCY R32 · 2RR

Dorothy Bell: Campbell-Stewart Anniversary Collection · Crib: E-cribs · Diagram: Keith Rose's Diagrams

- 1-- 1c+2c RHA ; LHA
- 9-- Circle4 and back
- 17-- 1W+2W turn RH ; 1M+2M turn LH
- 25-- All dance BtoB with opposite ; with NHJ slip L 3 steps/close to advance and pass | slip R to face next cpl.

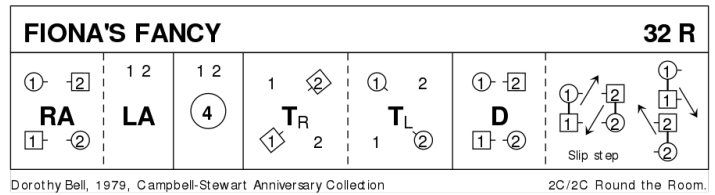

2 THE HAPPY MEETING J32 · 2/4L

RSCDS XXIX 9 · Crib: E-cribs · Diagram: Keith Rose's Diagrams

- 1-- 1M+2W cross and dance 3/4 Lsh round P, pass down/up Rsh, cast R round standing M/W to places
- 9-- 1W+2M repeat (other shoulders)
- 17-- 1c slip down the middle | set (1M starts L foot) ; slip to top | cast off (2c up)
- 25-- 2c+1c A&R (all clap) ; turn P RH

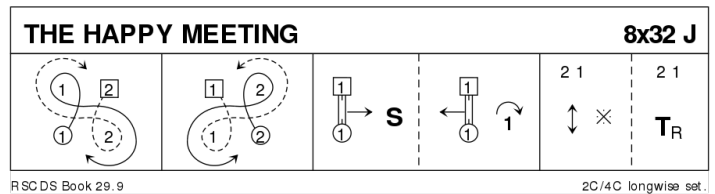

3 THE SILVER TASSIE S32 · 3/4L

John Drewry: The Leaflet Dances with Music · Crib: E-cribs · Diagram: Keith Rose's Diagrams

- 1-- 1c+2c+3c cross RH | set ; repeat
- 9-- 1c+3c DbIFig8 round 2c (1c cross down, 3c cast up)
- 17-- 1c followed by 2c+3c dance down the middle (2c & 3c divide) ; 1c (leading) +2c+3c dance up
- 25-- 1c+2c Rondel (2,1,3).

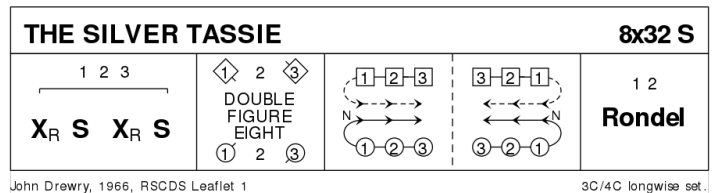

4 MRS MACLEOD R32 · 3/4L

RSCDS VI 11 · Crib: E-cribs · Diagram: Keith Rose's Diagrams

- 1-- 1c+2c RHA ; LHA
- 9-- 1c lead down the middle (2c up) ; and up to face 1cnrs
- 17-- 1c set to and turn corners, finish between corners
- 25-- Lsh Reels3{6} on the sides, 1c cross RH.

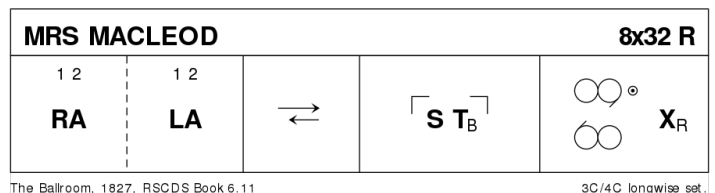

5 INCHMICKERY J32 · 5/5L

Roy Goldring: 14 Social Dances for 2000 · Crib: E-cribs · Diagram: Keith Rose's Diagrams

- 1- 1c+2c circle4 L ; 1c long cast to 3pl (2c+3c up) (2,3,1,4,5)
- 9- Teapots R ; and L (1c RHA with C on R ; LHA with C on L)
- 17- 1M+5W & 1W+2M Turn RH to places ; 1M+2W & 1W+5M repeat LH
- 25- 1c long cast to 5pl (4c+5c up) ; 5c+1c circle4 R (2,3,4,5,1)

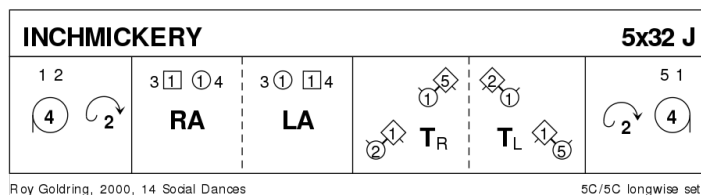

6 THE DUNDEE WHALER S32 · 4/4L

Roy Clowes: Ormskirk Scottish Dances - Memorial Edition · Crib: E-cribs · Diagram: Keith Rose's Diagrams

- 1- 2c+4c petronella (to 1,2x,3,4x)
- 9- 1c+2c & 3c+4c L-Chain
- 17- 1c+3c petronella (to 1x,2x,3x,4x)
- 25- 1W+2M cross LH | 1M+2W & 1W+3W cross RH ; 1M+3M & 1W+4M cross LH | 1M+4W cross RH (2,3,4,1).

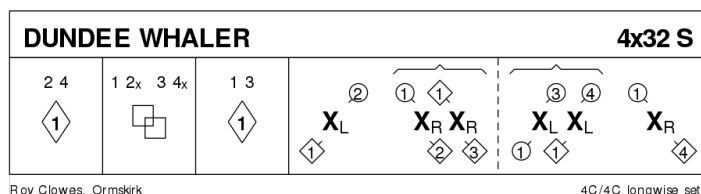

[25-32] represent tacking the ship, therefore no polite turns

7 CATCH THE WIND R32 · 3/4L

Romaine Butterfield: RSCDS XLV 5 · Crib: E-cribs · Diagram: Keith Rose's Diagrams

- 1- 1c set | cast off (2c up) ; ½Fig8 up (2,1x,3)
- 9- 1c set twice, on [11-12] 1W swivels R to face out ; 1W (1M following) casts R round 2M and down middle to finish 1W between 3c facing 3M, and 1M between 2c facing 2M.
- 17- 1M+2c & 1W+3c Rsh reels3 across
- 25- 1W (1M following) casts R round 3M and cross to 2pl ; 1c turn RH (2,1,3)

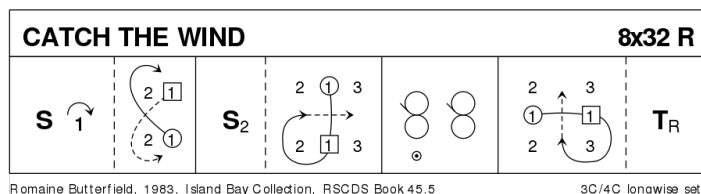

The original tune is a hornpipe

8 BILL CLEMENT MBE J32 · 3/4L

John Wilkinson: RSCDS XLVII 1 · Crib: E-cribs · Diagram: Keith Rose's Diagrams

- 1- 1c set | dance between 3c (2c up) and cast up to finish side by side LHJ facing 1cnr
- 9- Set to 1cnr and turn inwards and join RH | set to 3cnr ; turn 3cnr LH to face 2cnr RHJ
- 17- Set to 2cnr and turn inwards and join LH | set to 4cnr ; turn 4cnr RH to (2,1,3)
- 25- Circle6 and back

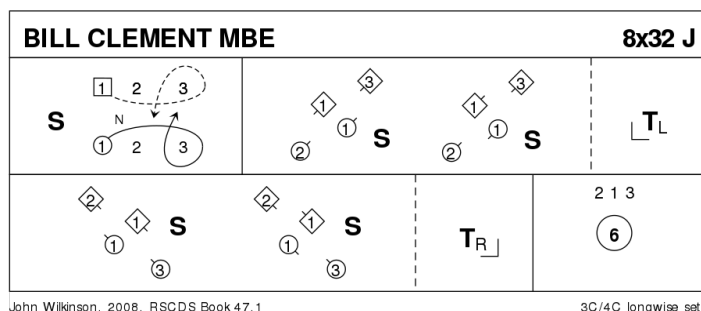

9 PROGRAMME ITEM – Interval

10 THE OLD MAN OF STORR R32 · 3/4L

Roy Goldring: *Scottish Country Dances for Children* · Crib: *E-cribs* · Diagram: *Keith Rose's Diagrams*

- 1– 1c+2c RHA, 1W ends facing out ; 1W (1M following) casts off (2c up) (2,1x,3)
- 9– 1c+3c LHA, 1W ends facing out ; 1W (1M following) casts off (3c up) (2,3,1)
- 17– 1c set, dance to top NHJ, cast off to 2pl (3c down on 21-22)
- 25– 2c+1c R&L

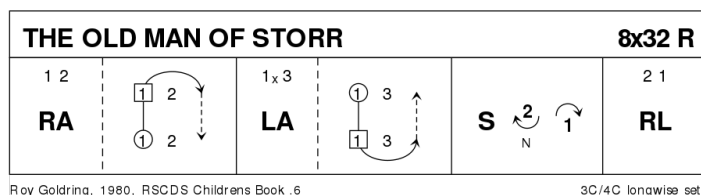

11 JOIE DE VIVRE J32 · 3/4L

Irene van Maarseveen: *RSCDS XXXIX 2* · Crib: *E-cribs* · Diagram: *Keith Rose's Diagrams*

- 1– 1c set | cast (2c up) ; dance between 3c and cast up to (2,1,3)
- 9– All turn P RH to sidelines ; all chase clw half round (to 3x,1x,2x)
- 17– All dance BtoB ; all set | all ½ RH turn into
- 25– 3c+1c+2c Allemande (2,1,3)

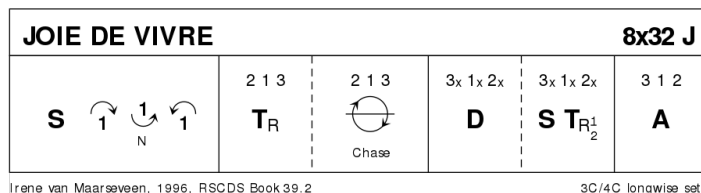

12 THE BELLE OF BON ACCORD S32 · 4/4L

John Drewry: *Deeside Book Part 2* · Crib: *E-cribs* · Diagram: *Keith Rose's Diagrams*

- 1– 1M cross, cast off round 2W to finish in the middle facing up **while{4}** 1W crosses between 2M and 3M, casts up to the middle facing down **while{4}** 3c do the same round 4c (2c & 4c step up ½ place) ; 1c+2c & 3c+4c RHA
- 9– 1c+3c Reel4 in the centre of the dance
- 17– 1c+3c turn ¾ RH to finish facing up NHJ **while{2}** 2c & 4c dance up ½ place on the sides and in to face down NHJ. All set ; 2c+1c & 4c+3c circle4 L (to sidelines 2,1x,4,3x)
- 25– 1c/3c lead up & cross between 2c/4c and cast off one ; 1c+3c turn BH, opening to face down | 1c dance to 4pl **while{2}** 3c cast up to 2pl. (2,3,4,1)

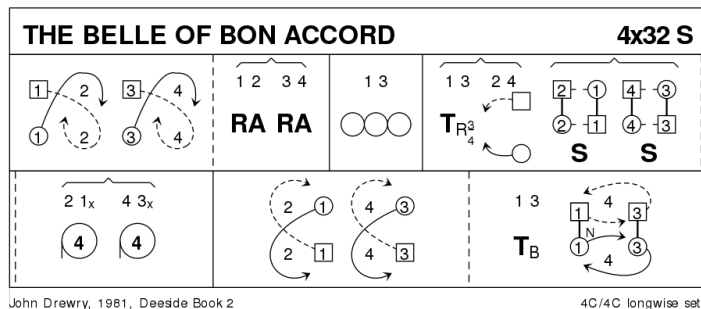

13 THE COLLEGE HORNPIPE R32 · 3/4L

W Boag (18C): RSCDS XX 12 · Crib: E-cribs · Diagram: Keith Rose's Diagrams

- 1- 1c+2c+3c circle6 and back, finishing in couples for
- 9- 1c+2c+3c Promenade
- 17- 1c cross RH, cast off one {3} cross LH, cast off one | lead up to face 1cnrs (2c up on [19-20])
- 25- 1c SetH&G with clap on [31] and Petronella Turn to own sideline

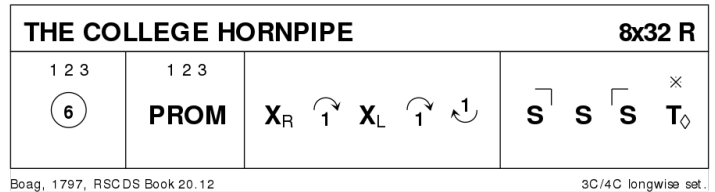

14 A CAPITAL JIG J32 · 3/4L

Tine E MacKay: Magazine Dances 2005-2009 · Crib: E-cribs · Diagram: Keith Rose's Diagrams

- 1- 1c+2c Set&Rotate, finish 1c facing 2c (2,1,3)
- 9- Rsh Reels3 on the sides
- 17- 1c set | turn $\frac{3}{4}$ RH ; 2c+1W & 1M+3c LHA (to 2,1x,3)
- 25- 1c set | turn $\frac{3}{4}$ RH ; 2c+1M & 1W+3c LHA (2,1,3)

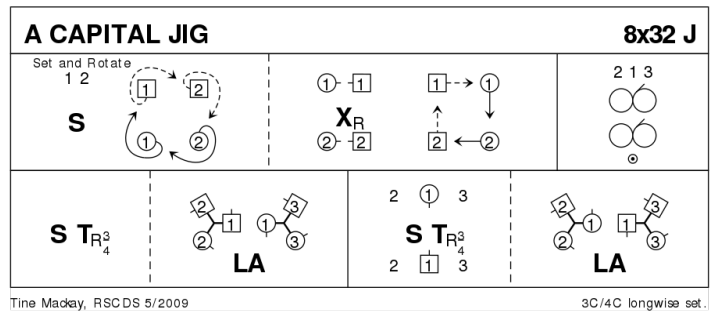

15 THE GENTLEMAN S32 · 3/4L

Roz Scott Huxley: RSCDS XXXV 5 · Crib: E-cribs · Diagram: Keith Rose's Diagrams

- 1- 2c step up as 1c turn BH to face P between them in line4 across | 1c+2c set, 1c advancing and passing on the second step ; $\frac{1}{2}$ Reel4, at end 1c pass LH to face down NHJ
- 9- 1c dance down to face P between 3c, repeat set and $\frac{1}{2}$ Reel4 with 3c, finish between 3c on own side LHJ
- 17- 1c lead to top, cross and cast to 2plx ; $\frac{1}{2}$ Reels3 across, Rsh to 4cnr (W up, M dn) (to 2,1,3)
- 25- 2c+1c Poussette.

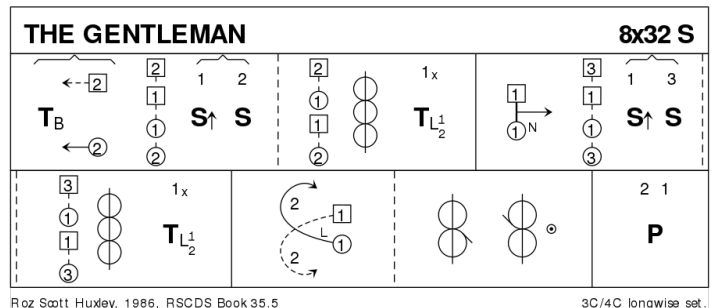

16 THE BARMKIN R88 · 4S

Roy Goldring: *A Second Book of Graded Scottish Country Dances* · Crib: *E-cribs* · Diagram: *Keith Rose's Diagrams*

- 1- 1c+3c turn RH and face clw ; chase ½ round set into
- 9- 3c+1c RHA ; LHA to exchanged places (3,2,1,4)
- 17-32 2c+4c repeat [1-16] (3,4,1,2)
- 33- 1c+3c turn LH and face cclw ; chase ½ round set to own places
- 41- 1c+3c R&L (1,4,3,2)
- 49-64 2c+4c repeat [33-48] (1,2,3,4)
- 65- All C NHJ advance | retire »diagonally« NHJ with cnr ; all W dance clw round their cnr
- 73- All pairs advance | retire NHJ with P to places ; all M dance clw round P
- 81- All circle8 and back

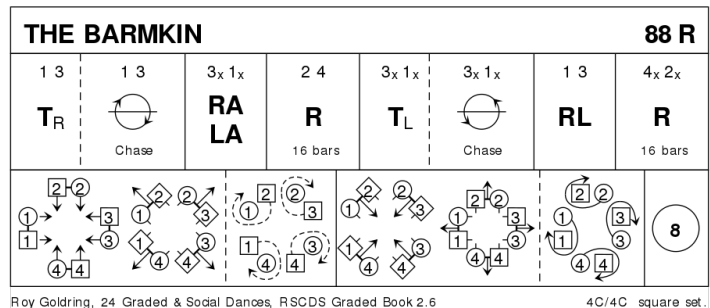

17 ESPIE MCNABB J32 · 3/4L

Miss Milligan's *Miscellany of Scottish Country Dances* · Crib: *E-cribs* · Diagram: *Keith Rose's Diagrams*

- 1- 1c+2c+3c set and cross RH ; repeat
- 9- 1c lead down the middle and up
- 17- 1c set | cast off (2c up) ; turn RH
- 25- 2c+1c+3c Circle6 and back

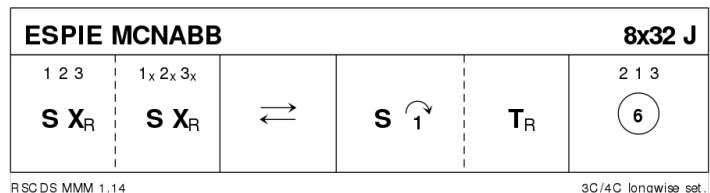

18 MRS STEWART'S JIG J32 · 3/4L

Frans Ligtmans: *RSCDS XXXV 1* · Crib: *E-cribs* · Diagram: *Keith Rose's Diagrams*

- 1- 1c set | 1W casts, 1M following, round 3W, 1W dances up round 3M and 1M dances up the middle, 1c face 3c (2c up on 7-8) (2,1x,3)
- 9- 2c+1c+3c G-Chain (2c cross), 2M+1M finish facing out
- 17- 2c+1c L-Chain
- 25- 2c+1c+3c A&R ; 1c turn RH 1½ to (2,1,3)

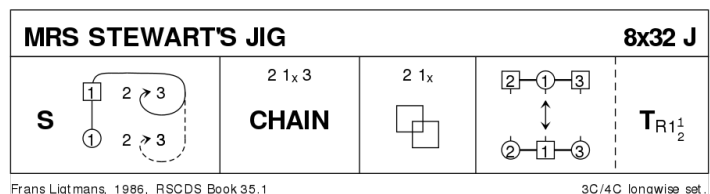

19 THE HIGHLAND RAMBLER R40 · 3/4L

Roy Goldring: *Silver Jubilee 25 - Leeds Branch* · Crib: *E-cribs* · Diagram: *Keith Rose's Diagrams*

- 1- 1c long cast to 2pl (2c up on [3-4] ; 1c+3c RHA (2,1,3)
- 9- 2c+1c LHA, 1W faces out ; 1W followed by 1M cast up round 2W and down the middle of set, 1W between 3c and 1M between 2c, all facing down
- 17- In lines of 3 down the middle (all swivel R) and up
- 25- 1M followed by 1W dance up, cast round 2W and into 2pl ; 1c turn RH
- 33- Circle6 and back

